

data buoy platforms

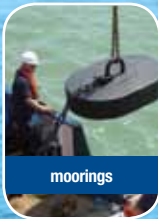

moorings



navigation buoys



hydrosphere



navigation lights

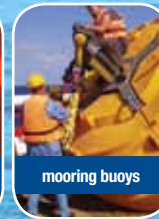

mooring buoys

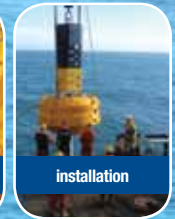

installation

the UK's leading supplier of aids to navigation

Mobilis JET 2000 J

2m diameter navigation buoy



MOBILIS

The JET 2000 J is a medium-size buoy suitable for use in nearshore locations where a highly visible navigation buoy is required.

The 1.9m diameter hull provides 2000Kg of buoyancy. It is constructed using two medium density polyethylene (MDPE) hull sections that surround a galvanised steel central structure, with a skirted base. This provides a very strong yet lightweight buoy that is easily handled by small craft and is an excellent alternative to traditional GLA Class 3, 4 and 5 steel buoys.

The modular design allows for sharing of parts with other buoys in the JET range so that a wide variety of daymarks, topmarks and navigation lights can be accommodated. Maintenance, inspection, replacement and spare holding costs are also greatly reduced.

The JET 2000 J is available as Cardinal, Lateral, Isolated Danger, Safe Water or Special Mark configurations and can be tailored to meet the individual requirements for navigation lights, solar panels and battery configurations.



navigation buoys

features:

- UV stabilised MDPE construction (does not require painting)
- Modular system - reduces spares holding
- Multiple mooring configurations including high current capability
- Wide range of navigation lights accepted
- Lightweight alternative to GLA Class 3, 4 and 5 steel buoys
- Selection of daymark assemblies accepted
- Interchangeable parts
- Built-in safety features such as a non-slip deck

buoy configurations

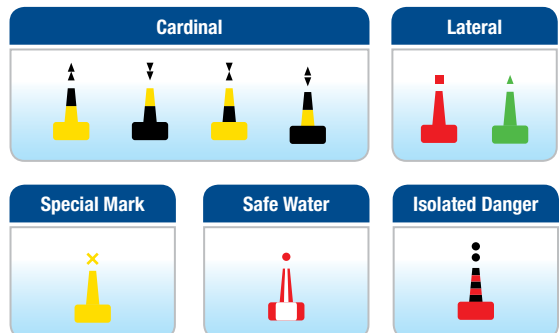

Mobilis JET 2000 J

specifications and applications

construction

Central Structure	Galvanised steel
Hull	MDPE (2 float sections)
Tower	Marine grade aluminium or MDPE
Daymark	MDPE
Topmark & Radar Reflector	Marine grade aluminium

physical

Diameter m	1.9
Mass Kg	650
Max Ballast Kg	160
Max Kg	810
Gross Buoyancy Kg	2000
Reserve Buoyancy Kg	1190
Focal Plane m	2.5
Draft m	0.8
Overall Height m	4.0

application

Inshore	✓
Estuary	✓
Coastal	✓
Offshore	

mooring

Type	Single Point / Bridle
Chain mm	20 - 25
Sinker Kg	2000 - 3000

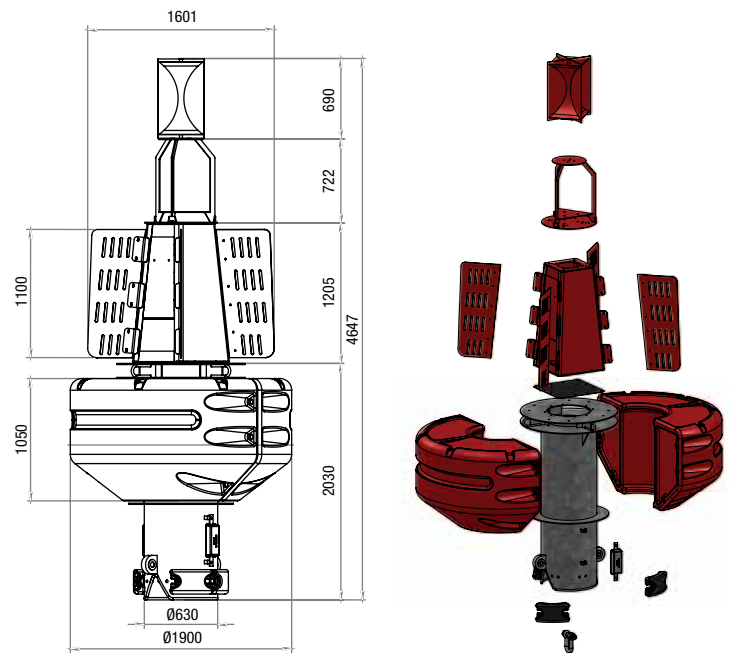

the right buoy for the job

To make sure you get the right buoy for your requirements consider all the factors that will affect the visibility and stability of the mark including: depth of water; sea conditions and current; lighting and range of light required; shape and topmarks; and focal plane.

mooring tips:

The mooring is an integral part of the system that will affect the performance and reliability of the buoy. On problematic locations we recommend a detailed mooring study be carried out to maximise reliability and minimise future maintenance costs.



hydrosphere

about Hydrosphere

Hydrosphere is the UK's leading supplier of aids to navigation and has been providing cost-effective solutions to the marine industry for more than 18 years. We offer a wide range of navigation and mooring buoys, LED navigation lights, sector lights, rotating beacons, leading lights, jetty masts, beach and zone marking products and associated moorings. Installation and maintenance services are available for all our products and systems.

For more information please contact us.

data buoy platforms | moorings | navigation buoys | navigation lights | mooring buoys | installation

t: +44 (0)1420 520374

www.hydrosphere.co.uk

e: sales@hydrosphere.co.uk

Compliant with all IALA recommendations.

